

SECTION B - B

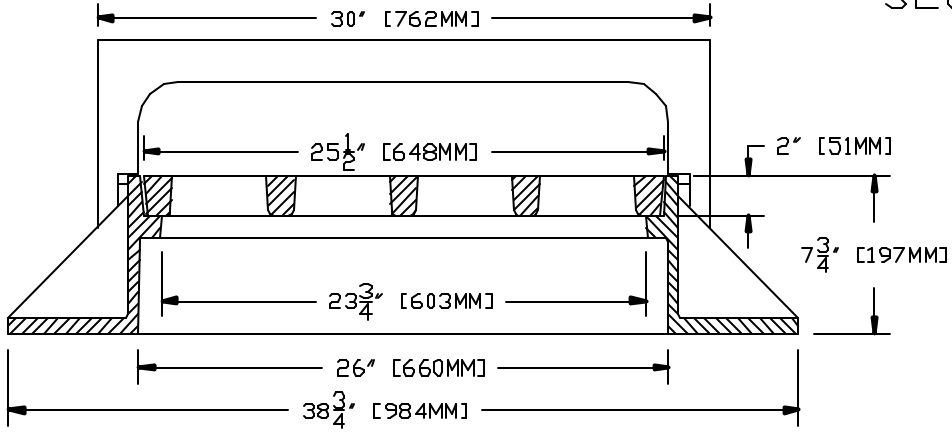

SECTION A - A

NOTES:

- 1.) MATERIAL SHALL BE GRAY CAST IRON CONFORMING TO A.S.T.M. A48 (LATEST REVISION) CLASS 30B.
- 2.) UNITS DESIGNED HEAVY DUTY FOR A.A.S.H.T.O. HS20-44 WHEEL LOADS.

THIS DOCUMENT IS THE PROPRIETARY PROPERTY OF SYRACUSE CASTINGS. IT HAS BEEN FURNISHED UPON THE CONDITION THAT IT SHALL NOT BE RELEASED, DUPLICATED, USED, OR DISCLOSED IN WHOLE OR IN PART FOR ANY PURPOSE WITHOUT THE EXPRESS WRITTEN PERMISSION OF SYRACUSE CASTINGS AND SHALL BE CONSIDERED CONFIDENTIAL INFORMATION.

Pattern 2627 Cast Iron
Frame, Grate & Curb

DRAWING # 2627000C-2627025C-2627100C

Drawn By: TJM DATE: 7/27/09 Revised By: Revised:

P.O. Box 1821
6177 South Bay Rd.
Cicero, N.Y. 13039

Phone # 315-699-2601 Fax # 315-699-2982 www.syracast.com