

SECTION - B

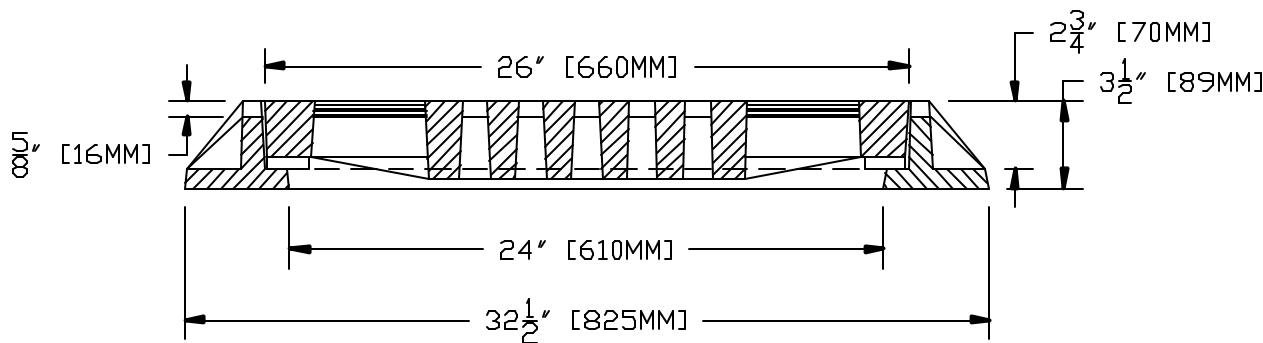

SECTION A - A

NOTES:

- 1.) MATERIAL SHALL BE GRAY CAST IRON CONFORMING TO A.S.T.M. A48 (LATEST REVISION) CLASS 30B.
- 2.) UNITS DESIGNED HEAVY DUTY FOR A.A.S.H.T.O. HS20-44 WHEEL LOADS.

THIS DOCUMENT IS THE PROPRIETARY PROPERTY OF SYRACUSE CASTINGS. IT HAS BEEN FURNISHED UPON THE CONDITION THAT IT SHALL NOT BE RELEASED, DUPLICATED, USED, OR DISCLOSED IN WHOLE OR IN PART FOR ANY PURPOSE WITHOUT THE EXPRESS WRITTEN PERMISSION OF SYRACUSE CASTINGS AND SHALL BE CONSIDERED CONFIDENTIAL INFORMATION.

Pattern 93359 Cast Iron  
Gutter Frame & Grate

DRAWING # 93359DOC-9335925C

Drawn By: TJM

DATE: 7/24/09

Revised By:

Revised:



**Syracuse Castings**

*Better By Design*

P.O. Box 1821  
6177 South Bay Rd.  
Cicero, N.Y. 13039

Phone # 315-699-2601 Fax # 315-699-2982 www.syracast.com