

PLAN VIEW

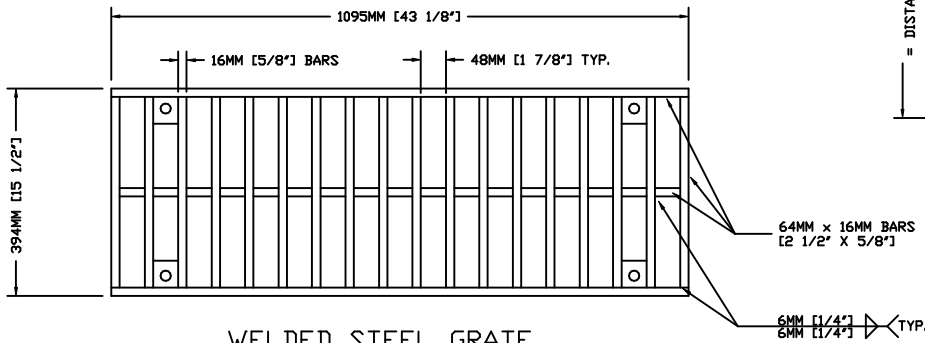

WELDED STEEL GRATE

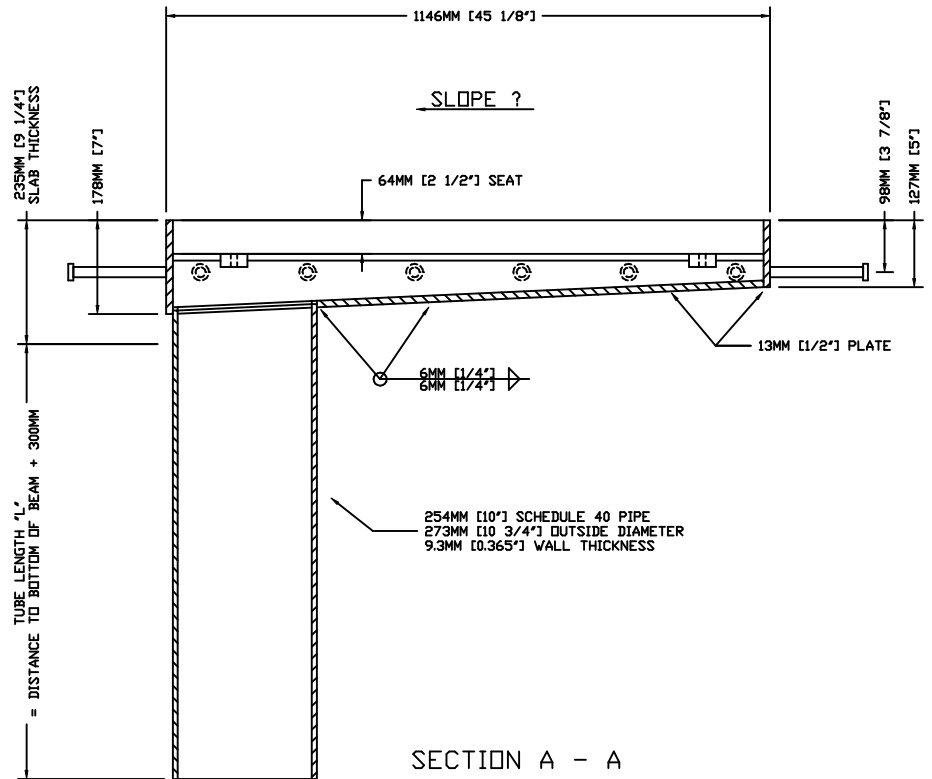

SECTION A - A

CONTRACTOR SHALL PROVIDE THE FOLLOWING :

VERIFY SLAB THICKNESS = 235MM [9 1/4"]

SLOPE OF BOX (PITCH OF ROAD) : \_\_\_\_\_

DOWNSPOUT LENGTH (DIMENSION "L") = \_\_\_\_\_

AUTHORIZED SIGNATURE: \_\_\_\_\_

DATE: \_\_\_\_\_

NOTES:

- 1.) MATERIAL FOR SCUPPER BOX AND GRATE SHALL BE HOT ROLLED STEEL CONFORMING TO A.S.T.M. A-36M (A.S.T.M. A709 GR. 250).
- 2.) STEEL TUBING SHALL CONFORM TO A.S.T.M. A500M GRADE B.
- 3.) COMPLETE UNIT SHALL BE HOT-DIP GALVANIZED PER A.S.T.M. A123 (NYS STANDARD SPEC SEC 719-01.).
- 4.) \_\_\_\_\_ SCUPPERS REQUIRED.

THIS DOCUMENT IS THE PROPRIETARY PROPERTY OF SYRACUSE CASTINGS. IT HAS BEEN FURNISHED UPON THE CONDITION THAT IT SHALL NOT BE RELEASED, DUPLICATED, USED, OR DISCLOSED IN WHOLE OR IN PART FOR ANY PURPOSE WITHOUT THE EXPRESS WRITTEN PERMISSION OF SYRACUSE CASTINGS AND SHALL BE CONSIDERED CONFIDENTIAL INFORMATION.

SC4014  
Galvanized Steel Bridge Scupper

DRAWING # SC4014

Drawn By: DM

DATE: 01/31/07

Revised By:

Revised:



**Syracuse Castings**  
Better By Design

P.O. Box 1821  
6177 South Bay Rd.  
Cicero, N.Y. 13039

Phone # 315-699-2601 Fax # 315-699-2982 www.syracast.com